Diffcalc Documentation

Release 8.4

Rob Walton

April 21, 2010

CONTENTS

1	Introduction	3
2	Quick-start inside OpenGda	5
2.1	Install	5
2.2	Start difcalc	5
3	Quick-Start outside OpenGDA	9
3.1	Setup environment	9
3.2	Start standalone	9
3.3	Start with minigda	10
4	Difcalc User Manual	13
4.1	Introduction	13
4.2	Overview	14
4.3	Getting Help	15
4.4	Difcalc's Scannables	16
4.5	Crystal orientation	17
4.6	Moving in hkl space	22
4.7	Scanning in hkl space	26
4.8	Thanks	27
5	Project Files & Directories	29
6	Indices and tables	31

Contents:

INTRODUCTION

Diffcalc is a diffraction condition calculator used for controlling diffractometers within reciprocal lattice space.

The core code will run by itself. However it makes more sense to use it within Diamond's Gda framework which provides motor control, a scan mechanism and more easily typed commands. An all-Python minimal framework, minigda, that provides just the latter two of these features is provided within this distribution.

Diffcalc is written in Python. It will run under either Python 2.2 or greater with the numpy module, or under Jython 2.2 with Java's Jama matrix package.

QUICK-START INSIDE OPENGDA

2.1 Install

Copy the Diffcalc folder into the gda root folder (i.e. so it sits alongside plugins, thirdparty etc.)

2.2 Start diffcalc

Diffcalc is started from the command line or it can be started in localStation automatically. To start a dummy sixcircle installation:

```
>>> diffcalc_path = gda.data.PathConstructor.createFromProperty("gda.root").split('/plugins')[0]
+ '/diffcalc'
>>> execfile(diffcalc_path + '/example/startup/sixcircle_dummy.py')
```

```
/scratch/ws/8_4/diffcalc added to GDA Jython path.
```

```
=====
Created DummyPD: alpha
Created DummyPD: delta
Created DummyPD: gamma
Created DummyPD: omega
Created DummyPD: chi
Created DummyPD: phi
Created diffractometer scannable: sixc
Created dummy energy scannable: en
Set dummy energy to 1 Angstrom
Created wavelength scannable: wl
Created hkl scannable: hkl
Created hkl component scannables: h, k & l
Created verbose hkl scannable: hklverbose. Reports virtual angles: 2theta, Bin, Bout, azimuth
Created parameter scannable: phi_par
Created parameter scannable: alpha_par
Created parameter scannable: oopgamma
Created parameter scannable: betaout
Created parameter scannable: azimuth
Created parameter scannable: betain
Created parameter scannable: blw
Aliased command: addref
Aliased command: autosector
Aliased command: calcub
Aliased command: checkub
Aliased command: dcversion
```

```
Aliased command: delref
Aliased command: editref
Aliased command: handleInputError
Aliased command: helpkl
Aliased command: helpub
Aliased command: hklmode
Aliased command: listub
Aliased command: loadub
Aliased command: mapper
Aliased command: newub
Aliased command: raiseExceptionsForAllErrors
Aliased command: saveubas
Aliased command: sector
Aliased command: setcut
Aliased command: setlat
Aliased command: setmax
Aliased command: setmin
Aliased command: setpar
Aliased command: setu
Aliased command: setub
Aliased command: showref
Aliased command: sigtau
Aliased command: sim
Aliased command: swapref
Aliased command: trackalpha
Aliased command: trackgamma
Aliased command: trackphi
Aliased command: transforma
Aliased command: transformb
Aliased command: transformc
Aliased command: ub
Aliased command: diffcalcdemo
```

=====
Try the following:

```
newub 'cubic'
setlat 'cubic' 1 1 1 90 90 90
pos wl 1
pos sixc [0 90 0 45 45 0]
addref 1 0 1
pos phi 90
addref 0 1 1
checkub
ub
hklmode
```

Or type 'diffcalcdemo' to run this script (Caution, will move the diffractometer!)

=====
Added objects/methods to namespace: gamma, trackalpha, phi, diffcalc_object, editref, transformc, newub, setub, setpar, transforma, setu, off, autosector, dcversion, betaout, sector, swapref, showref, setmin, trackgamma, ub, oopgamma, transformb, handleInputError, l, listub, chi, manual, helpub, helpkl, azimuth, wl, setlat, sim, trackphi, alpha, sigtau, omega, raiseExceptionsForAllErrors, saveubas, delref, hklmode, calcub, blw, k, setcut, en, diffcalcdemo, sixc, hklverbose, addref, h, delta, betain, setmax, auto, checkub, hkl, mapper, on, loadub, phi_par, alpha_par

Notice that this example script creates dummy scannables for the six axes and energy.

To use preexisting scannables modify:

```
diffcalcObjects = createDiffcalcObjects(  
    dummyAxisNames = ('alpha', 'delta', 'gamma', 'omega', 'chi', 'phi'),  
    dummyEnergyName = 'en',  
    geometryPlugin = 'sixc',  
    hklverboseVirtualAnglesToReport=('2theta','Bin','Bout','azimuth'),  
    demoCommands = demoCommands  
)  
  
to::  
  
diffcalcObjects = createDiffcalcObjects(  
    axisScannableList = (alpha, delta, gamma, omega, chi, phi),  
    energyScannable = en,  
    geometryPlugin = 'sixc',  
    hklverboseVirtualAnglesToReport=('2theta','Bin','Bout','azimuth'),  
    demoCommands = demoCommands  
)
```

Check out the user manual <doc/user/manual.html> . Also type `diffcalcdemo` to run the example session displayed above.

QUICK-START OUTSIDE OPENGDA

This is for those who want to use Diffcalc outside the gda. It might also help with development.

3.1 Setup environment

Change directory to the diffcalc project:

```
$ cd diffcalc
$ ls
BUGS.txt      diffcalc  example      #  RELEASE-NOTES.txt  THANKS.txt
COPYING.txt   docs     HISTORY.txt  README.txt   test
```

If using Python make sure numpy and diffcalc can be imported:

```
$ PYTHONPATH=$PYTHONPATH:<diffcalc_root>
$ python #use python2.4 at Diamond
Type "help", "copyright", "credits" or "license" for more information.
>>> import numpy
>>> import diffcalc
```

If using Jython make sure Jama and diffcalc can be imported:

```
$ jython -Dpython.path=<diffcalc_root>:<path_to_Jama>/Jama-1.0.1.jar

Jython 2.2.1 on java1.5.0_11
Type "copyright", "credits" or "license" for more information.
>>> import Jama
>>> import diffcalc
```

3.2 Start standalone

If you just want to try Diffcalc out as a user skip to the following section. To try out the code without using an external framework use the sixcircle.py example startup script (notice the -i):

```
$ python2.4 -i example/startup/sixcircle.py
>>> mon
BaseHarwdareMonitor:
  energy : 12.39842 keV
```

```

wavelength : 1.0 Angstrom
delta : 0.0 deg
gamma : 0.0 deg
omega : 0.0 deg
chi : 0.0 deg
phi : 0.0 deg
>>> dc.newub('demo')
>>> dc.setlat('xtal', 3.8401, 3.8401, 5.43072)
>>> mon.setWavelength(1.24)
>>> mon.setPosition((5.000, 22.790, 0.000, 1.552, 22.400, 14.255))
>>> dc.addref(1, 0, 1.0628)
>>> mon.setPosition((5.000, 22.790, 0.000, 4.575, 24.275, 101.320))
>>> dc.addref(0, 1, 1.0628)
Calculating UB matrix.

>>> dc.checkub()
    energy h    k    l    h_comp k_comp l_comp  tag
1  9.9987 1.00 0.00 1.06  1.0000 0.0000 1.0628
2  9.9987 0.00 1.00 1.06  -0.0329 1.0114 1.0400

>>> dc._hklToAngles(1,0,1.06) ((0.0, 23.281254709199715, 0.0,
11.640627354599907, 34.44739540990696, 3.21328587062226), {'Bin':
6.5535895349220628, 'theta': 70702.991919143591, 'Bout':
6.5535895349220628, '2theta': 23.281254709199715, 'azimuth':
4.6282344679186878})

>>> dc._anglesToHkl((0.0, 23.281254709199715, 0.0, 11.640627354599907,
34.44739540990696, 3.21328587062226)) ((0.9999999999999989,
-2.0078068981715935e-16, 1.0599999999999994), {'Bin': 1234, 'theta':
1234, 'Bout': 1234, '2theta': 1234, 'azimuth': 1234})

```

3.3 Start with minigda

The minigda framework in `diffcalc/external/minigda` provides a class `Scannable` of objects that can be moved or read in a scan, a `pos` command for moving or reading their positions, a `scan` command and a translator for mapping easy-to-type commands into method calls.

To install standalone or within the Minigda framework simply copy the projects directory somewhere handy. To install into the gda copy (or link) the `diffcalc` package (it should contain an `__init__.py` file) from within the main `diffcalc` project

To start the minigda:

```

$ python -t diffcalc/external/minigda/minigda.py
=====
Starting minigda on linux2 at Fri Jan 30 15:52:12 2009 ...
=====
sys.argv:  ['diffcalc/external/minigda/minigda.py']
=====
WARNING: No startup script specified.
Starting minigda terminal. Type exit or press ctrl-d to return to Python

gda>>>pos

```

Typing `pos` would display the scannables positions if there were any. Press `ctrl-d` to exit the translator into regular Python, and then `term.start()` to start again:

```
gda>>> pos
gda >>>dir()
Error: 'dir' is not an aliased command, Scannable, or comment.
(Hint: unlike the gda system, the minigda does not currently
support regular Python syntax.)
gda>>> exit
```

```
>>> dir()
['Pos', 'STARTUPSCRIPT', 'Scan', 'ScanDataPrinter',
'TerminalAliasedCommandsOnly', '__builtins__', '__doc__',
'__file__', '__name__', 'alias', 'main', 'os', 'pos', 'run',
'scan', 'sys', 'term', 'time', 'usage']
```

```
>>> term.start()
Starting minigda terminal. Type exit or press ctrl-d to return to Python
gda>>>
```

To tryout diffcalc within the minigda framework in earnest pass minigda the argument example/startup/sixcircle_with_scannables.py. With Jython for example:

```
$ jython -Dpython.path=/path_to_workspace/diffcalc/:path_to_workspace/...
... gda_trunk_for_diffcalc/jars/Jama-1.0.1.jar...
... -i diffcalc/external/minigda/minigda.py example/startup/sixcircle_with_scannables.py
=====
Starting minigda on javal.5.0_11 at Fri Feb 27 11:34:46 2009 ...
=====
sys.version: 2.2.1
os.getcwd(): /home/zrb13439/synched/workspace/diffcalc
=====
Running startup script 'example/startup/sixcircle_with_scannables.py' ...
```

WARNING: ExampleSixCircleStartup.py is not running within the GDA: falling back to the (very minimal) Starting minigda terminal. Type exit or press ctrl-d to return to Python

```
gda>>>pos
alpha: 0.0000
alpha_par:0.00000
azimuth: ---
betain: ---
betaout: ---
chi: 0.0000
cnt: 0.0000
delta: 0.0000
en: 12.3984
gamma: 0.0000
gamma_par:0.00000
h: Error: No UB matrix has been calculated during this ub calculation
hkl: Error: No UB matrix has been calculated during this ub calculation
k: Error: No UB matrix has been calculated during this ub calculation
l: Error: No UB matrix has been calculated during this ub calculation
omega: 0.0000
phi: 0.0000
phi_par: ---
sixc: alpha: 0.0000 delta: 0.0000 gamma: 0.0000 omega: 0.0000 chi: 0.0000 phi: 0.0000
wl: 1.0000
gda>>>
```

DIFFCALC USER MANUAL

Diffraction Condition Calculator for Diffractometer Control

Author Rob Walton

Contact rob.walton@diamond.ac.uk

Web site <http://opengda.org/>

This file is written in reStructuredText and can be compiled into html, latex, xml or open-document-format using Python's *Sphinx*.

4.1 Introduction

This manual assumes that you are running Diffcalc within the external framework of the GDA or Minigda and that Diffcalc has been configured for the six circle diffractometer pictured here:

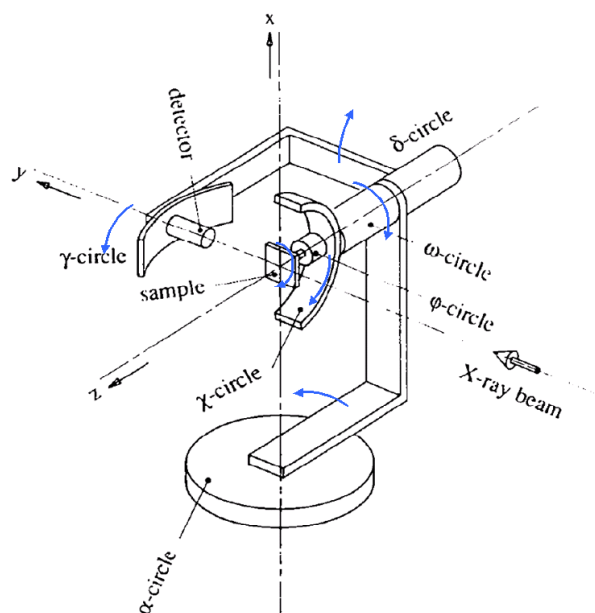

Figure 4.1: Gamma-on-delta six-circle diffractometer, modified from Elias Vlieg & Martin Lohmeier (1993)

Your Diffcalc configuration will have been customised for the geometry of your diffractometer and possibly the types of experiment you perform. For example: a five-circle diffractometer might be missing the Gamma circle above, some six-circle modes and the option to fix gamma that would otherwise exist in some modes.

The laboratory, crystal and reciprocal-lattice coordinate frames are defined with respect to the beam and to gravity to be (for a cubic crystal):



Figure 4.2: Laboratory and illustrative crystal coordinate frames for a cubic crystal

The crystal lattice basis vectors are defined within the Cartesian crystal coordinate frame to be:

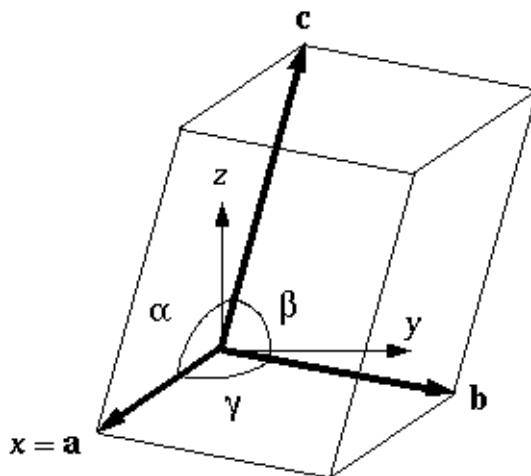

Figure 4.3: Unit cell defined in crystal coordinate frame

4.2 Overview

The following assumes that the diffractometer has been properly levelled, aligned with the beam and zeroed. See the [SPEC fourc manual](#).

Before moving in hkl space you must calculate a UB matrix by specifying the crystal's lattice parameters (which define the B matrix) and finding two reflections (from which the U matrix can be inferred); and, optionally for surface-diffraction experiments, determine how the surface of the crystal is oriented with respect to the phi axis.

Once a UB matrix has been calculated, the diffractometer may be driven in hkl coordinates. A valid diffractometer setting maps easily into a single hkl value. However for a diffractometer with more than three circles there are excess degrees of freedom when calculating a diffractometer setting from an hkl value. Diffcalc provides modes for using up the excess degrees of freedom.

Diffcalc does not perform scans directly. Instead, scannables that use diffcalc to map between reciprocal lattice space and real diffractometer settings are scanned using the Gda's (or minigda's) generic scan mechanism.

4.2.1 Theory

Thanks to Elias Vlieg for sharing his dos based DIF software that Diffcalc has borrowed heavily from. (See also the THANKS.txt file).

See the papers (included in docs/ref):

- Busing & Levi (1966), “Angle Calculations for 3- and 4- Circle X-ray and Neutron Diffractometers”, Acta Cryst. 22, 457
- Elias Vlieg & Martin Lohmeier (1993), “Angle Calculations for a Six-Circle Surface X-ray Diffractometer”, J. Appl. Cryst. 26, 706-716

4.3 Getting Help

There are few commands to remember. If a command is called without arguments, Diffcalc will prompt for arguments and provide sensible defaults which can be chosen by pressing enter.

The helpub and helphkl commands provide help with the crystal orientation and hkl movement phases of an experiment respectively:

```
>>> helpub
```

```
Diffcalc
-----
  helpub  ['command']      - lists all ub commands, or one if command is given
  helphkl ['command']      - lists all hkl commands, or one if command is given

UB State
-----
  newub  'name'           - starts a new ub calculation with no lattice or
                           reflection list
  loadub  'name'           - loads an existing ub calculation: lattice and
                           reflection list
  saveubas 'name'         - saves the ubcalculation with a new name (other
                           changes autosaved)
  ub      - shows the complete state of the ub calculation

UB lattice
-----
  setlat - prompts user to enter lattice parameters (in
          Angstroms and Deg.)
  setlat 'name' a         - assumes cubic
  setlat 'name' a b       - assumes tetragonal
  setlat 'name' a b c     - assumes ortho
  setlat 'name' a b c gam - assumes mon/hex with gam not equal to 90
  setlat 'name' a b c alpha beta gamma - arbitrary

UB surface
-----
  sigtau [sigma tau]     - sets sigma and tau

UB reflections
-----
  showref - shows full reflection list
  addref  - add reflection
  addref  h k l ['tag']  - add reflection with hardware position and energy
```

```

    addrf  h k l (p1,p2...pN) energy ['tag']- add reflection with specified position
                                                and energy
    delref  num                    - deletes a reflection (numbered from 1)
    swapref                    - swaps first two reflections used for calculating U
    swapref  num1 num2              - swaps two reflections (numbered from 1)

UB calculation
-----
    setu  [((,,),(,,),(,,))] - manually set u matrix
    setub  ((,,),(,,),(,,)) - manually set ub matrix
    calclub                    - (re)calculate u matrix from refl and refl2
    checkub                    - show calculated and entered hkl values for reflections

>>> helphkl

Diffcalc
-----
    helphkl [command]          - lists all hkl commands, or one if command is given
    helpub  [command]          - lists all ub commands, or one if command is given

Settings
-----
    hklmode [num]              - changes mode or shows current and available modes
                                and all settings
    setalpha [num]             - fixes alpha, or shows all settings if no num given
    setgamma [num]             - fixes gamma, or shows all settings if no num given
    setbetain [num]            - fixes betain, or shows all settings if no num given
    setbetaout [num]           - fixes betaout, or shows all settings if no num given
    trackalpha [boolean]       - determines wether alpha parameter will track alpha axis
    trackgamma [boolean]       - determines wether gamma parameter will track gamma axis
    trackphi [boolean]         - determines wether phi parameter will track phi axis
    setsectorlim [omega_high omega_low phi_high phi_low]- sets sector limits

Motion
-----
    pos  hkl [h k l]           - move diffractometer to hkl, or read hkl position.
                                Use None to hold a value still
    sim  hkl [h k l]           - simulates moving hkl
    hkl                                     - shows loads of info about current hkl position
    pos  sixc [alpha, delta, gamma, omega, chi, phi,]- move diffractometer to Eularian
                                                position. Use None to hold a
                                                value still
    sim  sixc [alpha, delta, gamma, omega, chi, phi,]- simulates moving sixc
    sixc                                     - shows loads of info about current sixc position

```

4.4 Diffcalc's Scannables

Please see the neighbouring manual, docs/users/scannables_manual.txt, for an introduction to scannables, the pos command and scanning. Also refer to Moving in hkl space and Scanning in hkl space below for some relevant examples.

To list and show the current positions of your beamline's scannables use pos with no arguments:

```
>>> pos
```

Results in:

Energy and wavelength scannables:

```
energy 12.3984
wl:    1.0000
```

Diffraction scannables, as a group and in component axes (in the real GDA these have limits):

```
sixc:    alpha: 0.0000 delta: 0.0000 gamma: 0.0000 omega: 0.0000 chi: 0.0000 phi: 0.0000
alpha:   0.0000
chi:     0.0000
delta:   0.0000
gamma:   0.0000
omega:   0.0000
phi:     0.0000
```

Dummy counter, which in this example simply counts at 1hit/s:

```
cnt:    0.0000
```

Hkl scannable, as a group and in component:

```
hkl:    Error: No UB matrix
h:      Error: No UB matrix
k:      Error: No UB matrix
l:      Error: No UB matrix
```

Parameter scannables, used in some modes, these provide a scannable alternative to the series of `fix` commands described in [Moving in hkl space](#):

```
alpha_par:0.00000
azimuth:  ---
betain:   ---
betaout:  ---
gamma_par:0.00000
phi_par:  ---
```

Note that where a parameter corresponds with a physical diffractometer axis, it can also be set to track that axis directly. See [Tracking axis](#) below.

4.5 Crystal orientation

Before moving in hkl space you must calculate a UB matrix by specifying the crystal's lattice parameters (which define the B matrix) and finding two reflections (from which the U matrix can be inferred); and, optionally for surface-diffraction experiments, determine how the surface of the crystal is oriented with respect to the phi axis (see [Overview](#)).

4.5.1 Starting a UB calculation

A *UB-calculation* contains the description of the crystal-under-test, any saved reflections, sigma & tau (both default to 0), and a B & UB matrix pair if they have been calculated or manually specified. Starting a new UB calculation will clear all of these.

Before starting a UB-calculation, the `ub` command used to summarise the state of the current UB-calculation, will reflect that no UB-calculation has been started:

```
>>> ub
No UB calculation started.
Wavelength: 1.239842
Energy: 10.000000
```

A new UB-calculation calculation may be started and lattice specified explicitly:

```
>>> newub 'b16_270608'
>>> setlat 'xtal' 3.8401 3.8401 5.43072 90 90 90
```

or interactively:

```
>>> newub
calculation name: b16_270608
crystal name: xtal
a [1]: 3.8401
b [3.8401]: 3.8401
c [3.8401]: 5.43072
alpha [90]: 90
beta [90]: 90
gamma [90]: 90
```

where a,b and c are the lengths of the three unit cell basis vectors in Angstroms, and alpha, beta and gamma the typically used angles (defined in the figure above) in Degrees.

The ub command will show the state of the current UB-calculation (and the current energy for reference):

```
UBCalc:      b16_270608
=====

Crystal
-----
name:        xtal

lattice:          a ,b ,c = 3.84010, 3.84010, 5.43072
                  alpha, beta , gamma = 90.00000, 90.00000, 90.00000

reciprocal:      b1, b2, b3 = 1.63620, 1.63620, 1.15697
                  beta1, beta2, beta3 = 1.57080, 1.57080, 1.57080

B matrix:        1.6362035642769 -0.0000000000000000 -0.0000000000000000
                  0.0000000000000000 1.6362035642769 -0.0000000000000000
                  0.0000000000000000 0.0000000000000000 1.156970955450

Reflections
-----
energy h    k    l    alpha    delta    gamma    omega    chi    phi    tag

UB matrix
-----
none calculated

Sigma: 0.000000
Tau:   0.000000
Wavelength: 1.000000
Energy: 12.398420
```

4.5.2 Specifying Sigma and Tau for surface diffraction experiments

Sigma and Tau are used in modes that fix either the beam exit or entry angle with respect to the crystal surface, or that keep the surface normal in the horizontal laboratory plane. For non surface-diffraction experiments these can safely be left at zero.

For surface diffraction experiments, where not only the crystal's lattice planes must be oriented appropriately but so must the crystal's optical surface, two angles `_Tau_` and `_Sigma_` define the orientation of the surface with respect to the phi axis. Sigma is (minus) the amount of chi axis rotation and Tau (minus) the amount of phi axis rotation needed to move the surface normal parallel to the omega circle axis. These angles are often determined by reflecting a laser from the surface of the Crystal onto some thing and moving chi and tau until the reflected spot remains stationary with movements of omega.

Use `sigtau` with no args to set interactively:

```
>>> pos chi -3.1
chi:      -3.1000
>>> pos phi 10.0
phi:      10.0000
>>> sigtau
sigma, tau = 0.000000, 0.000000
  chi, phi = -3.100000, 10.000000
sigma[ 3.1]: 3.1
  tau[-10.0]: 10.0
```

Sigma and Tau can also be set explicitly:

```
>>>sigtau 0 0
```

4.5.3 Managing reflections

The normal way to calculate a UB matrix is to find the position of **two** reflections with known hkl values. Diffcalc allows many reflections to be recorded but currently only uses the first two when calculating a UB matrix.

Add reflection at current location

It is normal to first move to a reflection:

```
>>> pos en 10
en:      10.0000
>>> pos sixc [5.000, 22.790, 0.000, 1.552, 22.400, 14.255]
sixc:    alpha: 5.0000 delta: 22.7900 gamma: 0.0000 omega: 1.5520 chi: 22.4000 phi: 14.2550
```

and then use the `addref` command either explicitly:

```
addref 1 0 1.0628 'optional_tag'
```

or interactively:

```
>>> addref
h: 1
k: 0
l: 1.0628
```

```
current pos[y]: y
tag: 'tag_string'
```

to add a reflection.

Add a reflection manually

If a reflection cannot be reached but its position is known (or if its position has been previously determined), a reflection may be added without first moving to it either explicitly:

```
>>> addrf 0 1 1.0628 [5.000, 22.790, 0.000,4.575, 24.275, 101.320] 'optional_tag'
```

or interactively:

```
>>> addrf
h: 0
k: 1
l: 1.0628
current pos[y]: n
  alpha[5.000]:
  delta[22.79]:
  gamma[0.000]:
  omega[1.552]: 4.575
  chi[22.40]: 24.275
  phi[14.25]: 101.320
  en[9.998]:
  tag: optional_tag2
```

Edit reflection list

Use `showref` to show the reflection list:

```
>>> showref
  energy h    k    l    alpha    delta    gamma    omega    chi    phi    tag
  1  9.999  1.00  0.00  1.06  5.0000  22.7900  0.0000  1.5520  22.4000  14.2550  1st
  2  9.999  0.00  1.00  1.06  5.0000  22.7900  0.0000  4.5750  24.2750  101.3200  2nd
```

Use `swapref` to swap reflections:

```
>>> swapref 1 2
Recalculating UB matrix.
>>> showref
  energy h    k    l    alpha    delta    gamma    omega    chi    phi    tag
  1  9.999  0.00  1.00  1.06  5.0000  22.7900  0.0000  4.5750  24.2750  101.3200  2nd
  2  9.999  1.00  0.00  1.06  5.0000  22.7900  0.0000  1.5520  22.4000  14.2550  1st
```

Use `delref` to delete a reflection:

```
>>> delref 1
>>> showref
  energy h    k    l    alpha    delta    gamma    omega    chi    phi    tag
  1  9.999  1.00  0.00  1.06  5.0000  22.7900  0.0000  1.5520  22.4000  14.2550  1st
```

4.5.4 Calculating a UB matrix

Unless a U or UB matrix has been manually specified, a new UB matrix will be calculated after the second reflection has been found, or whenever one of the first two reflections is changed.

Use the command `calcub` to force the UB matrix to be calculated from the first two reflections.

If you have misidentified a reflection used for the orientation the resulting UB matrix will be incorrect. Always use the `checkub` command to check that the computed values agree with the estimated values:

```
>>>checkub
      energy h      k      l      h_comp k_comp l_comp tag
1  9.9987 1.00 0.00 1.06  1.0000 0.0000 1.0628 1st
2  9.9987 0.00 1.00 1.06 -0.0329 1.0114 1.0400 2nd
```

Notice that the first reflection will always match, but that the second will not match exactly. (The system of equations used to calculate the U matrix is overdetermined and some information from the second reflection is thrown away.)

4.5.5 Manually setting U and UB

To help find the initial reflections it may be useful to set the U matrix manually—to the identity matrix for example. Use the `setu` command to do this. Once set the diffractometer may be driven to the ideal location of a reflection and then the actual reflection sought. Normally this would be done in the default mode, four-circle-bisecting, (see Moving in hkl space). In the following example this has been done by setting the alpha to 5 and leaving gamma at 0 (it would be normal to leave alpha at 0):

```
>>> hklmode 1
1) fourc bisecting
   alpha: 0.0
   gamma: 0.0

>>> setalpha 5
alpha: 0 --> 5.000000
>>> setu
row1[1 0 0]:
row2[0 1 0]:
row3[0 0 1]:
>>> sim hkl [1,0,1.0628] # Check it all makes sense
sixc would move to:
   alpha : 5.00000 deg
   delta : 22.79026 deg
   gamma : 0.00000 deg
   omega : 5.82845 deg
   chi : 24.57658 deg
   phi : 6.14137 deg

   theta : 70702.991919
2theta : 23.303705
   Bin : 6.969151
   Bout : 6.969151
azimuth : 7.262472

>>> pos hkl [1,0,1.0628]
hkl:      h: 1.00000 k: 0.00000 l: 1.06280

>>> # scan about to find actual reflection
```

```
>>> addref
h[0.0]: 1
k[0.0]: 0
l[0.0]: 1.0628
current pos[y]: y
tag: 'refl'
>>>
```

There is currently no way to refine a manually specified U matrix by inferring as much as possible from just one found reflection.

4.6 Moving in hkl space

Once a UB matrix has been calculated, the diffractometer may be driven in hkl coordinates. A given diffractometer setting maps easily into a single hkl value. However for a diffractometer with more than three circles there are excess degrees of freedom when calculating a diffractometer setting from an hkl value. Diffcalc provides many for using up the excess degrees of freedom.

By default Diffcalc selects four-circle bisecting mode (see below).

Note that to play along with the following run the file in `example/session/sixc_example.py` to configure the UB-calculation.

4.6.1 Modes

Use the command `hklmode` to summarise the state of Diffcalc's angle calculator. It shows a list the available modes for your diffractometer and the parameters that must be fixed for each, the current mode and the current parameter settings:

```
>>> hklmode
Available modes:
 0) fourc fixed-bandlw (alpha, gamma, blw) (Not impl.)
 1) fourc bisecting (alpha, gamma)
 2) fourc incoming (alpha, gamma, betain)
 3) fourc outgoing (alpha, gamma, betaout)
 4) fourc azimuth (alpha, gamma, azimuth) (Not impl.)
 5) fourc fixed-phi (alpha, gamma, phi) (Not impl.)
10) fivec bisecting (gamma)
11) fivec incoming (gamma, betain)
12) fivec outgoing (gamma, betaout)
13) fivec bisecting (alpha)
14) fivec incoming (alpha, betain)
15) fivec outgoing (alpha, betaout)
20) zaxis bisecting ()
21) zaxis incoming (betain)
22) zaxis outgoing (betaout)

Current mode:

1) fourc bisecting
Parameters:

  alpha: 0.0
  gamma: 0.0
```

```

betain: --- (not relevant in this mode)
betaout: --- (not relevant in this mode)
azimuth: --- (not relevant in this mode)
  phi: --- (not relevant in this mode)
  blw: --- (not relevant in this mode)

```

Note that ‘Not impl.’ is short for ‘not implemented’. Standby.

Your output may differ. For example:

- When listed with a typical five-circle diffractometer with no gamma circle: the fourc modes will have no gamma parameter to fix (actually it will have been fixed under the covers to 0), there will be no gamma or alpha parameters to fix in the five circle modes (again, under the covers gamma will have been fixed) and there will be no zaxis modes (as these require six circles, or an actual z-axis diffractometer).
- When listed with a typical four-circle diffractometer with no alpha or gamma circle, the four-circle modes will appear with no alpha or gamma parameters (again, they are fixed under the covers), and there will be no five circle or zaxis modes.

To change the current mode, call `hklmode` with an argument:

```

>>> hklmode 2
2) fourc incoming
  alpha: 0.0
  gamma: 0.0
  betain: ---

```

(The dashes next to the betain parameter indicate that a parameter has not yet been set.)

4.6.2 Mode parameters

A parameter can be set using either one of the series of `{{set}}` commands, by moving one of the scannables associated with each parameter or, where appropriate, by asking that a parameter track an axis.

Set commands

Use the series of commands `set<param_name>` to set a parameter:

```

>>> setalpha 3
alpha: 0 --> 3.000000
>>> setbetain 5
WARNING: The parameter betain is not used in mode 1
betain: --- --> 5.000000
>>> setalpha      # With no args, the current value is displayed
alpha: 3
>>> setbetain
betain: ---

```

Parameter Scannables

In most installations there will be a scannable for each parameter. In this example installation, the parameters which correspond to physical axes have had ‘_par’ appended to their names to prevent clashes. These may be used to change a parameter either with the `pos` command or by using them within a scan (see Scanning in hkl space).:

```
>>> pos betain
betain: 0.00000
>>> pos betain 5
betain: 5.00000
>>> setbetain
betain: 5

>>> pos alpha_par
alpha_par:3.00000
>>> setalpha
alpha: 3
```

Tracking Axis

Where a parameter matches an axis name, that parameter may be set to track that axis:

```
>>> pos alpha
alpha: 5.0000

>>> hklmode 1
1) fourc bisecting
   alpha: 0.0
   gamma: 0.0

>>> trackalpha
alpha: 5

>>> pos alpha
alpha: 6.0000

>>> hklmode 1
1) fourc bisecting
   alpha: 6.0 (tracking physical axis)
   gamma: 0.0
```

Although convenient, there is a danger with this method that in geometries where the axes are built from other axes (such as in a kappa geometry), the position of an axis may drift slightly during a scan.

4.6.3 Sectors

When mapping from reciprocal lattice space to a set of diffractometer settings, there is normally a choice of solutions for the sample orientation. The selected sector mode will determine which solution is used. There is currently only one sector mode:

Sector mode: Find first solution within sector limits

In this sector mode, taken from 'DIF', the first solution found within the 'sector limits' is chosen. These are different from the physical or software limits on the axes and can be checked/modified using `setsectorlim`:

```
>>> setsectorlim
omega_high[270]:
omega_low[-90]:
```

```
phi_high[180]:
phi_low[-180]:
```

4.6.4 The hkl scannable

Once a UB matrix has been calculated, a mode chosen and parameters set, use the hkl scannable to move to a point in reciprocal lattice space:

```
>>> pos hkl [1,0,0]
hkl:      h: 1.00000 k: -0.00000 l: -0.00000
>>> pos sixc
sixc:     alpha: 3.0000 delta: 17.2252 gamma: 4.0000 omega: 7.5046 chi: -24.6257 phi: 4.8026
>>> pos hkl
hkl:      h: 1.00000 k: -0.00000 l: -0.00000
>>> hkl
hkl:
      h : 1.000000
      k : -0.000000
      l : -0.000000
  2theta : 18.582618
      Bin : -0.387976
      Bout : -0.387976
  azimuth : 1.646099
```

Notice that typing hkl will also display some virtual angles (such as twotheta and Bin), that checking the position with pos hkl will not.

To get this extra information into a scan use the scannable hklverbose instead of hkl:

```
>>> pos hklverbose [1,0,0]
hklverbose:      h: 1.00000 k: -0.00000 l: -0.00000 2theta : 18.582618 Bin : -0.387976
                Bout : -0.387976 azimuth : 1.646099
```

The sim command will report, without moving the diffractometer, where an hkl position would be found:

```
>>> sim hkl [1,0,0]
sixc would move to:
  alpha : 3.00000 deg
  delta : 17.22516 deg
  gamma : 4.00000 deg
  omega : 7.50461 deg
  chi : -24.62568 deg
  phi : 4.80260 deg

  theta : 70702.991919
  2theta : 18.582618
  Bin : -0.387976
  Bout : -0.387976
  azimuth : 1.646099
```

Moving out of range

Not every hkl position can be reached:

```
>>> pos hkl [10,10,10]
Exception: Could not compute delta for this hkl position
```

4.6.5 The diffractometer scannable (sixc)

We've seen this before, but it also works with sim:

```
gda>>>sim sixc [3, 17.22516, 4, 7.50461, -24.62568, 4.80260]
hkl would move to:
  h : 1.000000
  k : 0.000000
  l : -0.000000
```

4.7 Scanning in hkl space

All scans described below use the same generic scanning mechanism provided by the GDA system or by minigda. Here are some examples.

4.7.1 Fixed hkl scans

In a 'fixed hkl scan' something (such as energy or Bin) is scanned, and at each step hkl is 'moved' to keep the sample and detector aligned. Also plonk the diffractometer scannable (sixc) on there with no destination to monitor what is actually happening and then throw on a detector (cnt) with an exposure time if appropriate:

```
>>> #scan scannable_name start stop step [scannable_name [pos or time]]..
>>> scan en 9 11 .5 hkl [1,0,0] sixc cnt 1
>>> scan en 9 11 .5 hklverbose [1,0,0] sixc cnt 1
>>> scan betain 4 5 .2 hkl [1,0,0] sixc cnt 1
>>> scan alpha_par 0 10 2 hkl [1,0,0] sixc cnt 1
>>> trackalpha
>>> scan alpha 0 10 2 hkl [1,0,0] sixc cnt 1 # Equivalent to last scan
```

4.7.2 Scanning hkl

Hkl, or one component, may also be scanned directly:

```
>>> scan h .8 1.2 .1 hklverbose sixc cnt 1
```

At each step, this will read the current hkl position, modify the h component and then move to the resulting vector. There is a danger that with this method k and l may drift. To get around this the start, stop and step values may also be specified as vectors. So for example:

```
>>> scan hkl [1,0,0] [1,.3,0] [1,0.1,0] cnt1
```

is equivalent to:

```
>>> pos hkl [1,0,0]
>>> scan k 0 .3 .1 cnt1
```

but will not suffer from drifting. This method also allows scans along any direction in hkl space to be performed.

4.7.3 Multidimension scans

Two and three dimensional scans:

```
>>> scan en 9 11 .5 h .9 1.1 .2 hklverbose sixc cnt 1
>>> scan h 1 3 1 k 1 3 1 l 1 3 1 hkl cnt 1
```

Good luck — RobW

4.8 Thanks

I would like to acknowledge the people who have made a direct impact on the Diffcalc project, knowingly or not, in terms of encouragement, suggestions, criticism, bug reports, code contributions, and related projects:

- Elias Vlieg — writer of DIF software used as a model for Diffcalc
- Spec
- Diamond
- Chris Nicklin
- Allesandro Bombardi
- Steve Collins
- Martin Lohmier And Elias Vlieg
- Busang & Levi

Thank you!

PROJECT FILES & DIRECTORIES

diffcalc The project source directory, installed as a Python package.

docs This project documentation directory. The documentation is written in reStructuredText and can be compiled into html and pdf using Python's [Sphinx](#).

docs/ref Includes pdfs of relevant papers.

tests Unit tests. Not required to use the software, but very useful if you're planning to modify it.

example Example startup scripts.

models VrmI models of diffractometers (not tied into diffcalc or OpenGda yet).

INDICES AND TABLES

- *Index*
- *Module Index*
- *Search Page*